

MODEL 501 SERIES
SHOWN LEFT SIDE
MODEL 502 SERIES
SHOWN RIGHT SIDE
AXLE ASSEMBLY IS ONLY DIFFERENCE BETWEEN
501/502 SERIES DOORS

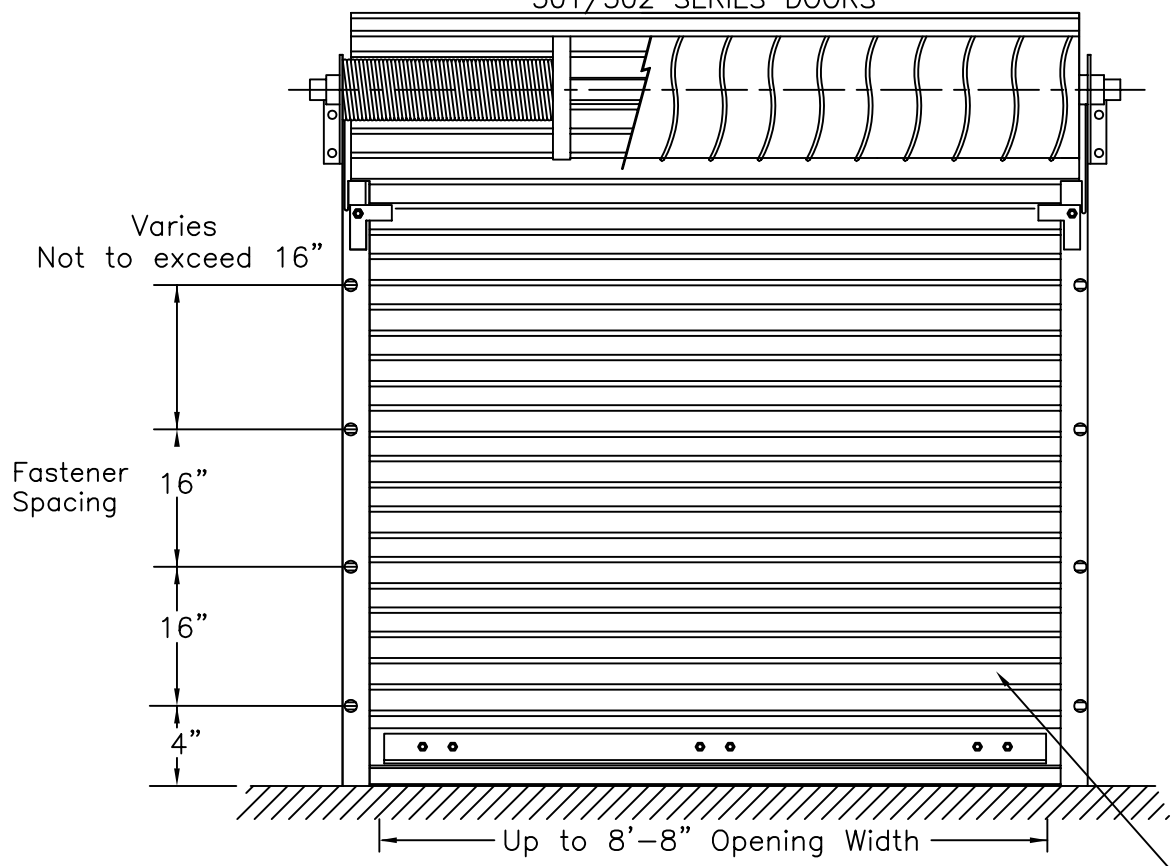

INTERIOR ELEVATION

Scale: None

Guide Fastener Spacing Same for Both Guides.

Door Curtain: .017±.001 Hot Dip Galvanized Steel ASTM A-653 Structural Steel (Grade 80) With Full Coat Of Primer And Baked Polyester Finish Coat.

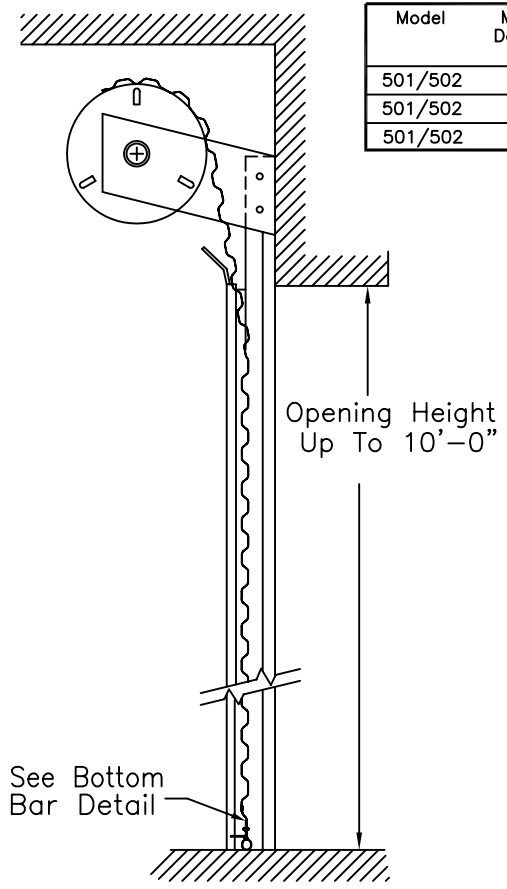
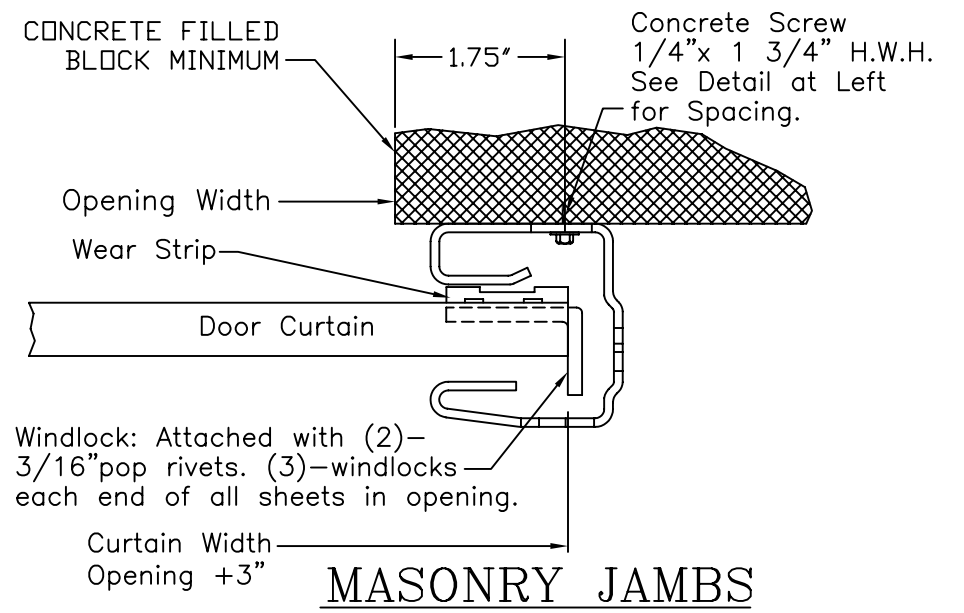
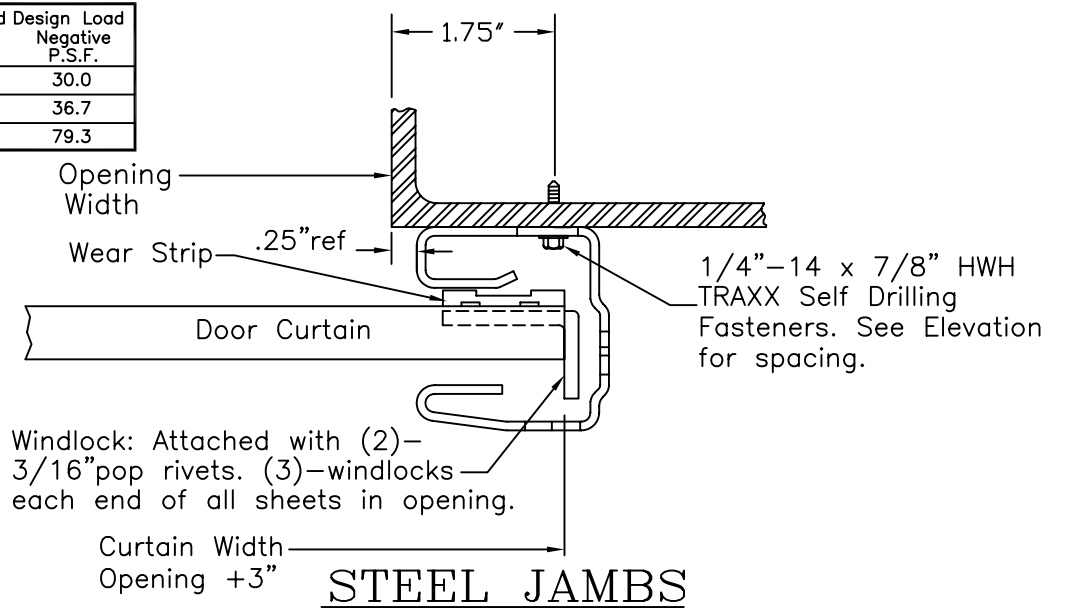

TABLE 1

Model	Maximum Door Width	Maximum Door Height	Design Load Positive P.S.F.	Design Load Negative P.S.F.
501/502	8'-8"	10'-0"	28.0	30.0
501/502	8'-0"	10'-0"	34.4	36.7
501/502	6'-0"	10'-0"	75.8	79.3



Refer to test report
CTLA 1927W-1

Doors designed for 28 #/ft² POS. and 30 #/ft² NEG. PSF wind load
Maximum door size 8'-8" wide x 10'-0" high

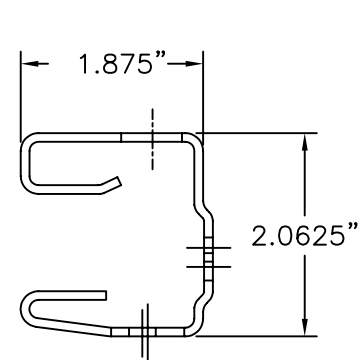

DOOR GUIDE

Material: CS type "B"
G40 Thickness .054"

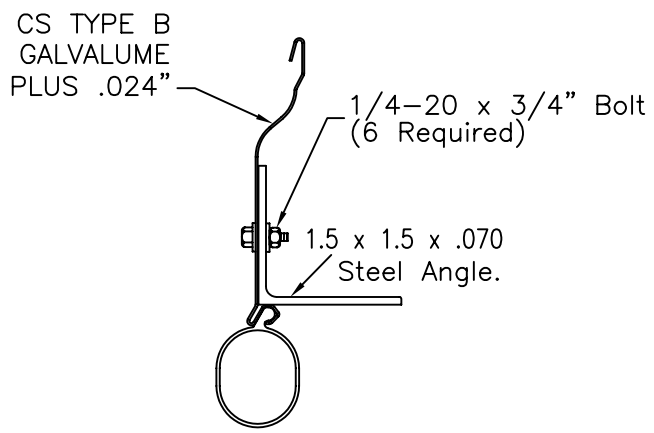

BOTTOM BAR

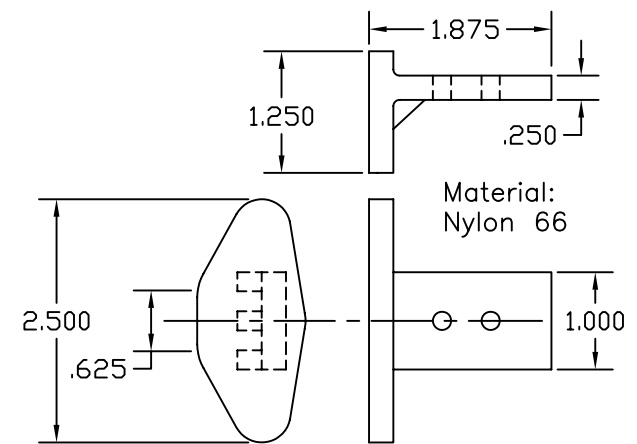

WIND LOCK P/N U220011

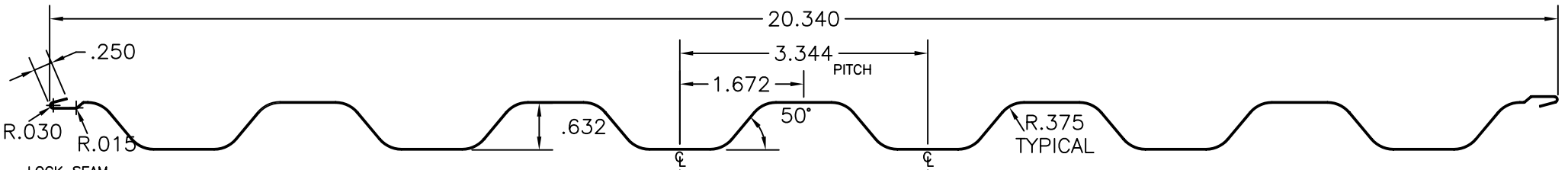

CORRUGATED SHEET

Scale: None

MODEL 501/502-30

	JOB: _____	DATE: 1/06/08 SHEET: 1 of 2
	CONTRACTOR: _____	DRAWN BY: C.D.W.
	ARCHITECT: _____	CHECKED BY: G.O.G.
	ADDRESS: _____	DRAWING NUMBER
10407 Rocket Blvd. Orlando Fl. 32824	DISTRIBUTOR: _____	501/502-30-104
407.859.6770 Fax 407.447.2923 usdoor.com	ADDRESS: _____	

02/27/09